

SECTION **SB**  
SEAT BELT SYSTEM

A  
B  
C  
D  
E  
F  
G  
SB  
I  
J  
K  
L  
M  
N  
O  
P

CONTENTS

<b>PRECAUTION</b> .....	2	<b>FRONT SEAT BELT</b> .....	6
<b>PRECAUTIONS</b> .....	2	Exploded View .....	6
Precaution for Supplemental Restraint System (SRS) "AIR BAG" and "SEAT BELT PRE-TEN- SIONER" .....	2	Removal and Installation .....	6
Precaution for Seat Belt Service .....	2	<b>REAR SEAT BELT</b> .....	8
<b>BASIC INSPECTION</b> .....	3	Exploded View .....	8
<b>COMPONENT INSPECTION</b> .....	3	Removal and Installation .....	8
Inspection .....	3	<b>LATCH SYSTEM FOR CHILDREN</b> .....	10
<b>ON-VEHICLE REPAIR</b> .....	6	Removal and Installation .....	10
		<b>TOP TETHER STRAP CHILD RESTRAINT</b> .....	11
		Removal and Installation .....	11

# PRECAUTIONS

< PRECAUTION >

## PRECAUTION

### PRECAUTIONS

#### Precaution for Supplemental Restraint System (SRS) "AIR BAG" and "SEAT BELT PRE-TENSIONER"

INFOID:000000005809548

The Supplemental Restraint System such as "AIR BAG" and "SEAT BELT PRE-TENSIONER", used along with a front seat belt, helps to reduce the risk or severity of injury to the driver and front passenger for certain types of collision. This system includes seat belt switch inputs and dual stage front air bag modules. The SRS system uses the seat belt switches to determine the front air bag deployment, and may only deploy one front air bag, depending on the severity of a collision and whether the front occupants are belted or unbelted. Information necessary to service the system safely is included in the SR and SB section of this Service Manual.

#### **WARNING:**

- To avoid rendering the SRS inoperative, which could increase the risk of personal injury or death in the event of a collision which would result in air bag inflation, all maintenance must be performed by an authorized NISSAN/INFINITI dealer.
- Improper maintenance, including incorrect removal and installation of the SRS, can lead to personal injury caused by unintentional activation of the system. For removal of Spiral Cable and Air Bag Module, see the SR section.
- Do not use electrical test equipment on any circuit related to the SRS unless instructed to in this Service Manual. SRS wiring harnesses can be identified by yellow and/or orange harnesses or harness connectors.

#### PRECAUTIONS WHEN USING POWER TOOLS (AIR OR ELECTRIC) AND HAMMERS

#### **WARNING:**

- When working near the Airbag Diagnosis Sensor Unit or other Airbag System sensors with the Ignition ON or engine running, DO NOT use air or electric power tools or strike near the sensor(s) with a hammer. Heavy vibration could activate the sensor(s) and deploy the air bag(s), possibly causing serious injury.
- When using air or electric power tools or hammers, always switch the Ignition OFF, disconnect the battery, and wait at least 3 minutes before performing any service.

#### Precaution for Seat Belt Service

INFOID:000000005440337

#### **CAUTION:**

- Before removing the front seat belt pre-tensioner assembly, turn the ignition switch off, disconnect both 12-volt battery terminals and wait at least 3 minutes.
- Do not use electrical test equipment for front seat belt pre-tensioner connector.
- After replacing or reinstalling front seat belt pre-tensioner assembly, or reconnecting front seat belt pre-tensioner connector, check the system function. Refer to [SRC-12, "SRS Operation Check"](#).
- Do not disassemble buckle or seat belt assembly.
- Replace anchor bolts if they are deformed or worn out.
- Never oil tongue and buckle.
- If any component of seat belt assembly is questionable, do not repair. Replace the whole seat belt assembly.
- If webbing is cut, frayed, or damaged, replace seat belt assembly.
- When replacing seat belt assembly, use a genuine NISSAN seat belt assembly.

# COMPONENT INSPECTION

< BASIC INSPECTION >

## BASIC INSPECTION

### COMPONENT INSPECTION

Inspection

INFOID:000000005440338

#### AFTER A COLLISION

##### **WARNING:**

**Inspect all seat belt assemblies including retractors and attaching hardware after any collision. NISSAN/INFINITI recommends that all seat belt assemblies in use during a collision be replaced unless the collision was minor and the belts show no damage and continue to operate properly. Failure to do so could result in serious personal injury in an accident. Seat belt assemblies not in use during a collision should also be replaced if either damage or improper operation is noted. Seat belt pre-tensioned should be replaced even if the seat belts are not in use during a frontal collision in which the air bags are deployed.**

Replace any seat belt assembly (including anchor bolts) if:

- The seat belt was in use at the time of a collision (except for minor collisions and the belts, retractors and buckles show no damage and continue to operate properly).
- The seat belt was damaged in an accident. (i.e. torn webbing, bent retractor or guide, etc.)
- The seat belt attaching point was damaged in an accident. Inspect the seat belt attaching area for damage or distortion and repair as necessary before installing a new seat belt assembly.
- Anchor bolts are deformed or worn out.
- The seat belt pre-tensioner should be replaced even if the seat belts are not in use during the collision in which the air bags are deployed.

#### PRELIMINARY CHECKS

1. Check the seat belt warning lamp/chime for proper operation as follows:
  - a. Switch ignition ON. The seat belt warning lamp should illuminate. Also, the seat belt warning chime should sound for about six seconds.
  - b. Fasten driver's seat belt. The seat belt warning lamp should go out and the chime (if sounding) should stop.
2. If the air bag warning lamp is blinking, conduct self-diagnosis using CONSULT-III, and air bag warning lamp. Refer to [SRC-12, "SRS Operation Check"](#).
3. Check that the seat belt retractor, seat belt anchor and buckle bolts are securely attached.
4. Check the shoulder seat belt guide and shoulder belt height adjuster for front seats. Make sure guide swivels freely and that webbing lays flat and does not bind in guide. Make sure height adjuster operates properly and holds securely.
5. Check retractor operation:
  - a. Fully extend the seat belt webbing and check for twists, tears or other damage.
  - b. Allow the seat belt to retract. Make sure that webbing returns smoothly and completely into the retractor. If the seat belt does not return smoothly, wipe the inside of the loops with a clean paper cloth. Dirt built up in the loops of the upper anchors can cause the seat belts to retract slowly.
  - c. Fasten the seat belt. Check that the seat belt returns smoothly and completely to the retractor. If the webbing does not return smoothly, the cause may be an accumulation of dust or dirt. Use the "SEAT BELT TAPE SET" and perform the following steps.

Inspect the front seat belt through-anchor

1. Pull the seat belt out to a length of 500 mm (19.69 in) or more.
2. Use a clip or other device to hold the seat belt at the center pillar webbing opening.
3. Pass a thin wire through the through-anchor webbing opening. Hold both ends of the wire and pull it taut while moving it up and down several times along the webbing opening surface to move matter stuck there.
4. Any dirt that can not be removed with the wire can be removed by cleaning the opening with a clean cloth.
5. Apply tape at the point where the webbing contacts the through-anchor webbing opening.

**NOTE:**  
Apply the tape so that there is no looseness or wrinkling.
6. Remove the clip holding the seat belt and check that the webbing returns smoothly.

# COMPONENT INSPECTION

## < BASIC INSPECTION >

- Repeat steps above as necessary to check the other seat belts.

### SEAT BELT RETRACTOR ON-VEHICLE CHECK

Emergency Locking Retractors (ELR) and Automatic Locking Retractors (ALR)

#### NOTE:

All seat belt retractors are of the Emergency Locking Retractors (ELR) type. In an emergency (sudden stop) the retractor will lock and prevent the webbing from extending any further. All 3-point type seat belt retractors except the driver's seat belt also have an Automatic Locking Retractors (ALR) mode. The ALR mode (also called child restraint mode) is used when installing child seats. The ALR mode is activated when the seat belt is fully extended. When the webbing is then retracted partially, the ALR mode automatically locks the seat belt in a specific position so the webbing cannot be extended any further. To cancel the ALR mode, allow the seat belt to fully wind back into the retractor.

Check the seat belt retractors using the following test(s) to determine if a retractor assembly is operating properly.

#### ELR Function Stationary Check

Grasp the shoulder webbing and pull forward quickly. The retractor should lock and prevent the belt from extending further.

#### ALR Function Stationary Check

- Pull out entire length of seat belt from retractor until a click is heard.
- Retract the webbing partially. A clicking noise should be heard as the webbing retracts indicating that the retractor is in the Automatic Locking Retractors (ALR) mode.
- Grasp the seat belt and try to pull out the retractor. The webbing must lock and not extend any further. If NG, replace the retractor assembly.
- Allow the entire length of the webbing to retract to cancel the automatic locking mode.

#### ELR Function Moving Check

#### WARNING:

**Perform the following test in a safe, open area clear of other vehicles and obstructions (for example, a large, empty parking lot). Road surface must be paved and dry. DO NOT perform the following test on wet or gravel roads or on public streets and highways. This could result in an accident and serious personal injury. The driver and passenger must be prepared to brace themselves in the event the retractor does not lock.**

- Fasten driver's seat belt. Buckle a passenger into the seat for the belt that is to be tested.
- Proceed to the designated safe area.
- Drive the vehicle at approximately 16 km/h (10 MPH). Notify any passengers of a pending sudden stop and the driver and passenger must be prepared to brace themselves in the event the retractor does not lock, apply brakes firmly and make a very hard stop.

During stop, seat belts should lock and not be extended. If the seat belt retractor assembly does not lock, perform the retractor off-vehicle check.

### SEAT BELT RETRACTOR OFF-VEHICLE CHECK (PILLAR MOUNTED)

- Remove the seat belt retractor.
  - Remove the front seat belt assembly, refer to [SB-6, "Removal and Installation"](#).
- Slowly pull out webbing while tilting the retractor assembly forward from the mounted position without twisting the retractor assembly as shown in the illustration.

**A** : The webbing can be pulled out in case the retractor is tilted 15° degree or less.

**B** : The webbing can not be pulled out if the retractor is tilted 35° degrees or more.

- A and B show tilting angles.

- ↔ : Vehicle front.

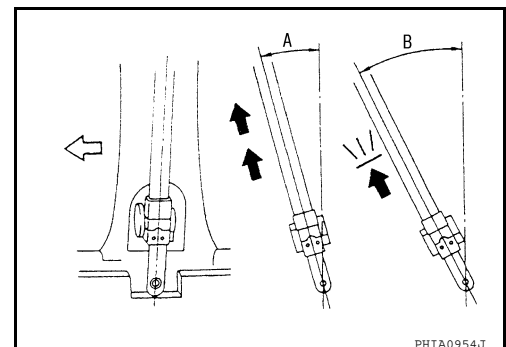

PHIA0954J

# COMPONENT INSPECTION

## < BASIC INSPECTION >

Replace the seat belt assembly if it does not operate within specifications.

### SEAT BELT RETRACTOR OFF-VEHICLE CHECK (REAR PARCEL SHELF MOUNTED)

1. Remove the seat belt retractor.
  - Remove the rear seat belt assembly, refer to [SB-8, "Removal and Installation"](#).
2. Slowly pull out webbing while tilting the retractor assembly forward from the mounted position without twisting the retractor assembly as shown in the illustration.

**A** : The webbing can be pulled out in case the retractor is tilted 15° degree or less.

**B** : The webbing can not be pulled out if the retractor is tilted 35° degrees or more.

- A and B show tilting angles.
- ← : Vehicle front.

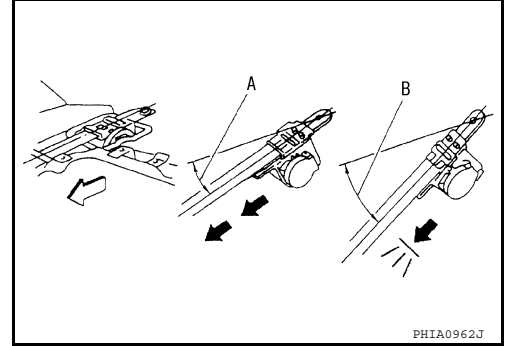

Replace the seat belt assembly if it does not operate within specifications.

A  
B  
C  
D  
E  
F  
G  
I  
J  
K  
L  
M  
N  
O  
P

SB

# FRONT SEAT BELT

< ON-VEHICLE REPAIR >

## ON-VEHICLE REPAIR

### FRONT SEAT BELT

Exploded View

INFOID:000000005440339

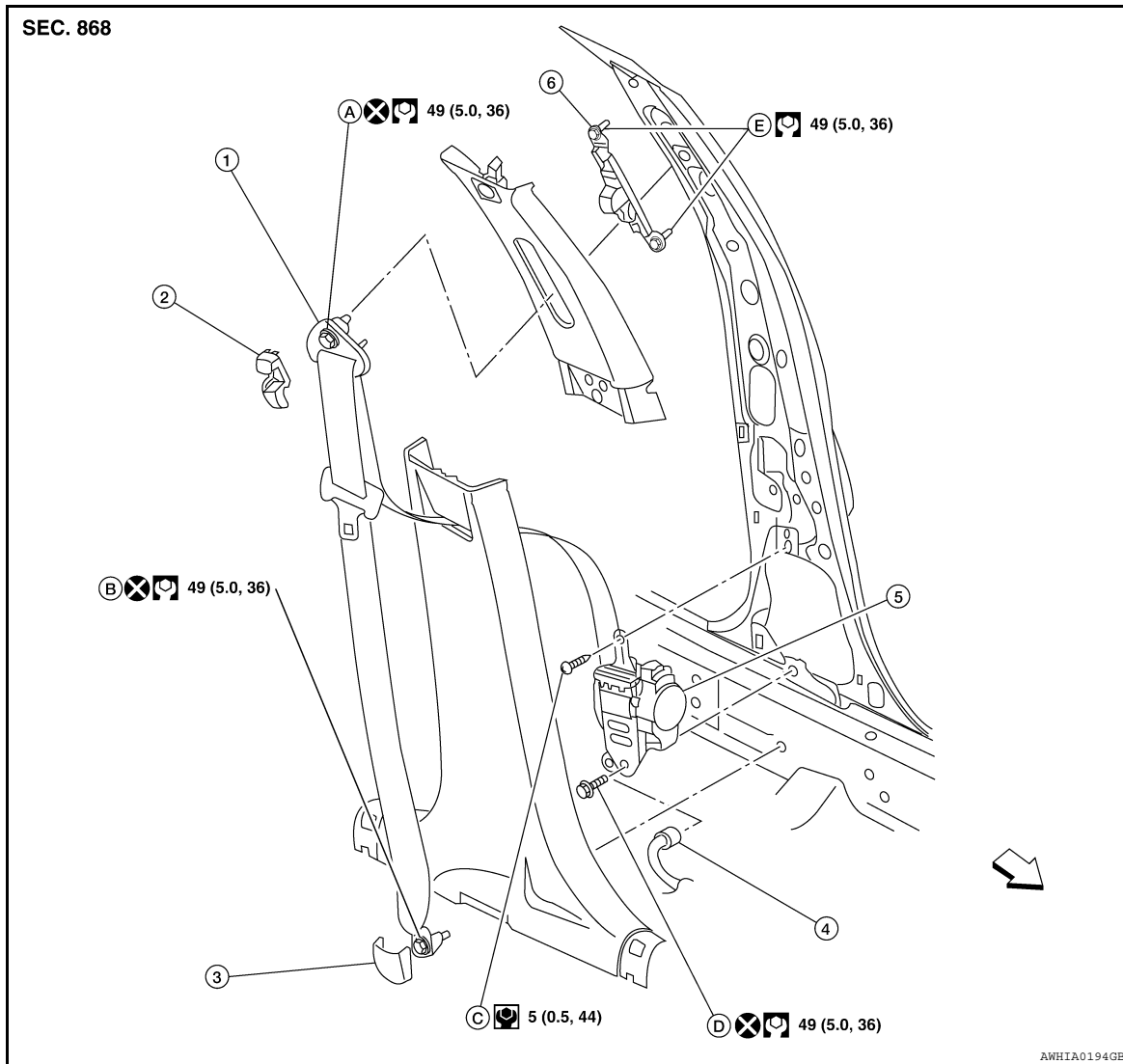

- |                                      |                        |                            |
|--------------------------------------|------------------------|----------------------------|
| 1. D-ring anchor                     | 2. Adjuster cover      | 3. Outer anchor bolt cover |
| 4. Seat belt pre-tensioner connector | 5. Seat belt retractor | 6. Seat belt adjuster      |
| A. D-ring anchor bolt                | B. Outer anchor bolt   | C. Retractor screw         |
| D. Retractor anchor bolt             | E. Bolt                | ← Vehicle front            |

## Removal and Installation

INFOID:000000005440340

### REMOVAL - RETRACTOR

#### CAUTION:

**Before servicing SRS, turn the ignition switch off, disconnect the 12-volt battery negative and positive terminals, then wait at least 3 minutes.**

1. Disconnect the 12-volt battery negative and positive terminals, then wait at least 3 minutes.
2. Release the pawl, then remove outer anchor bolt cover and outer anchor bolt.
3. Remove center pillar lower finisher. Refer to [INT-19, "Removal and Installation"](#).
4. Remove D-ring anchor bolt from seat belt adjuster.

# FRONT SEAT BELT

## < ON-VEHICLE REPAIR >

- Remove seat belt retractor.
  - Disconnect the seat belt pre-tensioner connector.

**CAUTION:**

- For installing/removing seat belt pre-tensioner connector, insert a thin screwdriver wrapped with tape into the notch; lift locking tab then remove connector.
- Install connector with lock raised, then push locking tab into connector.

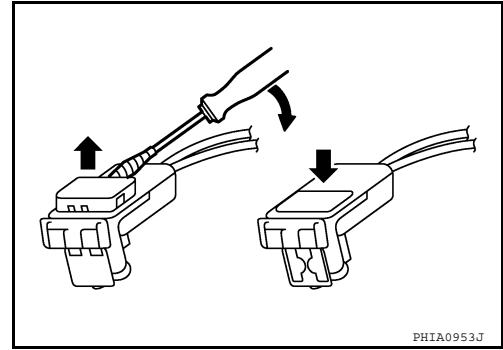

- Remove screw and retractor anchor bolt, then remove seat belt retractor from center pillar.

### INSTALLATION - RETRACTOR

Installation is in the reverse order of removal.

- Always perform an inspection after repair to be sure the system is functioning within specifications. Refer to [SB-3, "Inspection"](#).

### REMOVAL - BUCKLE

**CAUTION:**

Before servicing SRS, turn the ignition switch off, disconnect the 12-volt battery negative and positive terminals, then wait at least 3 minutes.

- Disconnect the 12-volt battery negative and positive terminals.
- Remove the front seat from the vehicle. Refer to [SE-22, "Removal and Installation"](#).
- Remove anchor nut (A) from the seat belt buckle (1).
- Disconnect the seat belt buckle harness connector (2), release the harness clip(s), then remove the seat belt buckle (1).

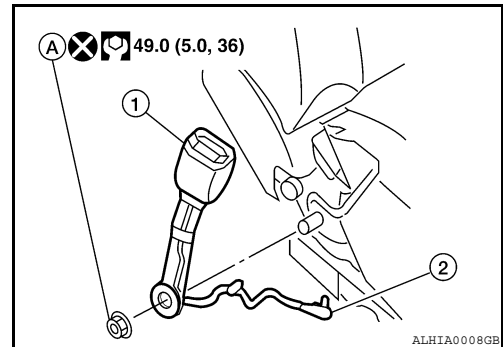

### INSTALLATION - BUCKLE

Installation is in the reverse order of removal.

- Always perform an inspection after repair to be sure the system is functioning within specifications. Refer to [SB-3, "Inspection"](#).

# REAR SEAT BELT

< ON-VEHICLE REPAIR >

## REAR SEAT BELT

Exploded View

INFOID:000000005440341

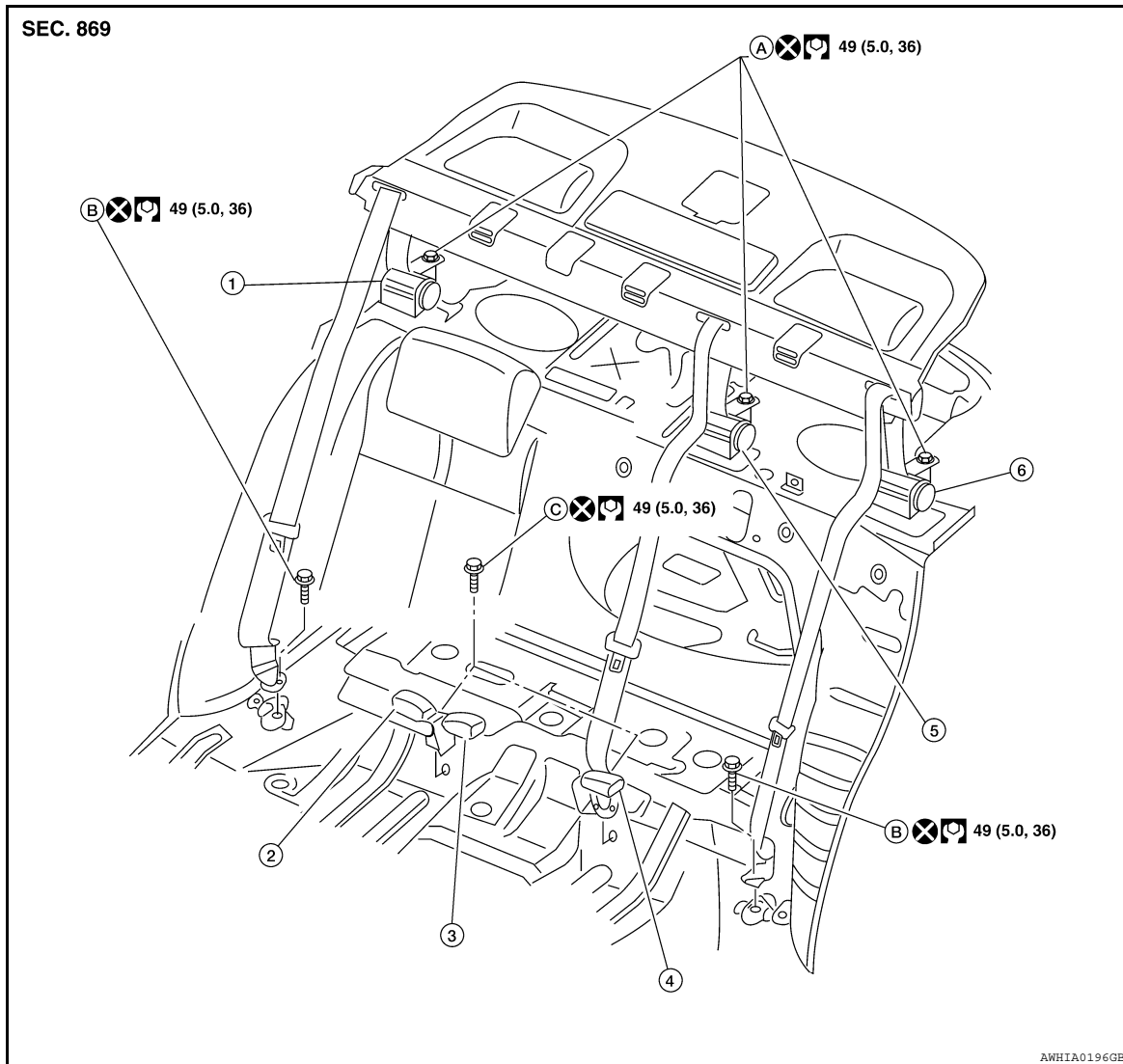

- |                           |                               |                            |
|---------------------------|-------------------------------|----------------------------|
| 1. Seat belt retractor RH | 2. Seat belt buckle RH        | 3. Seat belt buckle center |
| 4. Seat belt buckle LH    | 5. Seat belt retractor center | 6. Seat belt retractor LH  |
| A. Retractor anchor bolt  | B. Outer anchor bolt          | C. Buckle anchor bolt      |

### Removal and Installation

INFOID:000000005440342

#### REMOVAL - RETRACTOR

1. Remove the rear seat cushion. Refer to [SE-24, "Removal and Installation"](#).
2. Remove the outer anchor bolt (outer belt retractor) or buckle anchor bolt (center belt retractor).
3. Remove the rear parcel shelf finisher. Refer to [INT-22, "Removal and Installation"](#).
4. Remove retractor anchor bolt, then remove seat belt retractor.

#### INSTALLATION - RETRACTOR

Installation is in the reverse order of removal.

- Always perform an inspection after repair to be sure the system is functioning within specifications. Refer to [SB-3, "Inspection"](#).

#### REMOVAL - BUCKLE



## REAR SEAT BELT

### < ON-VEHICLE REPAIR >

---

1. Remove the rear seat cushion. Refer to [SE-24, "Removal and Installation"](#).
2. Remove buckle anchor bolt, then remove the seat belt buckle.

### INSTALLATION - BUCKLE

Installation is in the reverse order of removal.

- Always perform an inspection after repair to be sure the system is functioning within specifications. Refer to [SB-3, "Inspection"](#).

A

B

C

D

E

F

G

SB

I

J

K

L

M

N

O

P

# LATCH SYSTEM FOR CHILDREN

< ON-VEHICLE REPAIR >

## LATCH SYSTEM FOR CHILDREN

### Removal and Installation

INFOID:000000005440343

**NOTE:**

The LATCH (Lower Anchors and Tether for Children) system is a built-in part of the vehicle structure, and is not servicable.

- ↩ Vehicle front

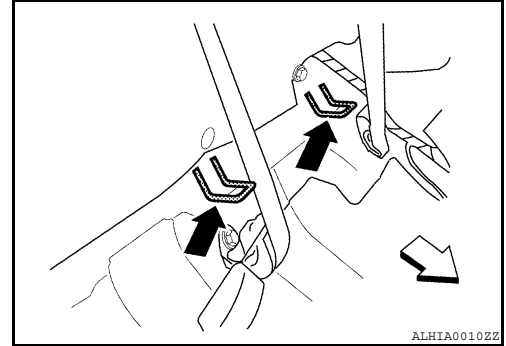

# TOP TETHER STRAP CHILD RESTRAINT

< ON-VEHICLE REPAIR >

## TOP TETHER STRAP CHILD RESTRAINT

### Removal and Installation

INFOID:000000005440344

**NOTE:**

The Top Tether Strap Child Restraint is a built-in part of the vehicle structure, and is not serviceable.

- ← Vehicle front

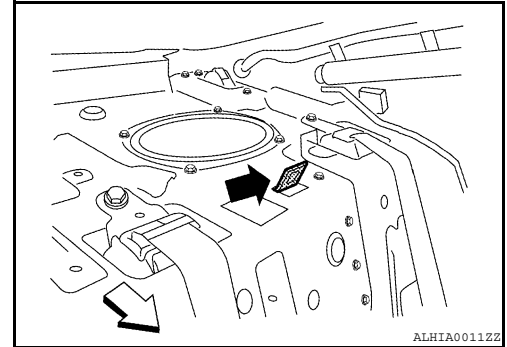

A  
B  
C  
D  
E  
F  
G  
SB  
I  
J  
K  
L  
M  
N  
O  
P